

K12 Barrier Lift System up to 10m CWO

The K12 Barrier Lift System (BLS) provides reliable high-security against unauthorised vehicle access. With the units reliable and quick operation, it offers an immediate protection against vehicles attempting to break-through.

MAIN FEATURES

- Crash Tested and certified according to DOS
- Completely destroys the chassis of any vehicle trying to break-through
- Blocking height up to 1100mm
- Unobtrusive and flushed with the road in lowered position
- Tri-Protect® anti-corrosion protection coating
- Environmentally Friendly biodegradable oil*

*optional feature

Design

Barrier Lift System with electro-hydraulic drive in separate drive cabinet, guide stands, ground sleeves, horizontal crash beam and ground frame for installation in roadway.

Impact Energy

1699 kJ (6.8 t @ 50 mph) Crash test certified according to; DOS SD-STD-02.01 Rev. A 03/2003 K12/L2

Clear Width of Opening (CWO)

6000-10000mm in 1000mm increments

Blocking Height

1100mm

Crash Beam

Rectangular hollow section profile RHS 450x250 with cover plate

Guide Stands HxWxD

2213 x 1293 x 571mm (height without hydraulic cylinder), height above foundation: 1713mm

Ground Frame LxWxH

(CWO + 24mm) x 880 x 310 mm (width without anchors, height without 150mm high drainage sleeves)
Total width approx. 1013mm

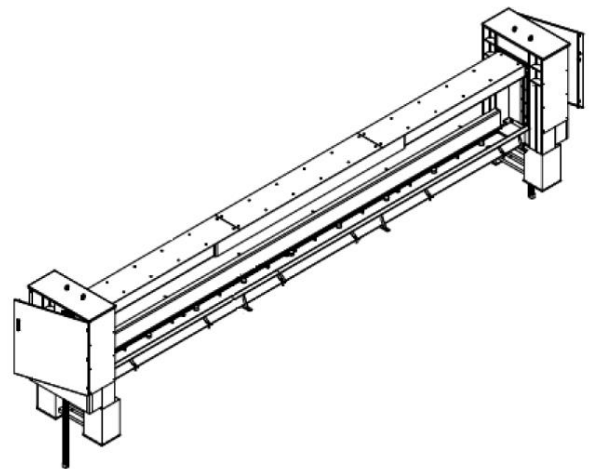

Ground Sleeves HxWxD

654 x 1370 x 400mm (height without fastening bolts, depth without sleeve for hollow pipe connection)

Drive Cabinet HxWxD

1400 x 1200 x 400mm incl. 200mm high base
(standard/RO1 for non-EU and non-EFTA countries)
1800 x 1200 x 500mm incl. 200mm high base (RO1 for EU and EFTA countries)

Emergency Operation:

Via hand pump (standard) Accumulator incl. rechargeable batteries for one movement (RO1) (optional)

Operating Speed:

Raising: approx. 0.17 m/sec
Lowering: approx. 0.20 m/sec

Wheel Load:

100 kN according to SLW60 – DIN 1072

Drive:

4.0 kW, 400 V (three-phase), 50 Hz

Hydraulic Fluid

Mineral oil HLP 22 or biodegradable oil Plantohyd 22 S, non-hazardous to water

Control Unit

PLC in control box installed in drive cabinet (standard), PLC in separate control box for wall mounting inside a building (optional), control voltage 24 V

Supply Voltage

400 V (3Ph + N + PE), 50 Hz

Weight:

Approx. 1610 – 2130kg (crash beam)
Approx. 2560kg (guide stands and ground sleeves)
Approx. 650 – 960kg (ground frame)
Approx. 280 – 400kg (drive cabinet)

Finish

Barrier

RAL Tri-Protect®: Long-term anti-corrosion protection coating according to DIN 55633 corrosion category C5, high durability and C5-industrial and marine atmosphere, medium durability respectively (Industrial areas with high humidity and aggressive atmospheres and Marine, offshore, estuaries, coastal areas with high salinity).

Post./Housing

RAL Tri-Protect®: Long-term anti-corrosion protection coating according to DIN 55633 corrosion category C4: Industrial areas (e.g. chemical plants) and coastal areas with moderate salinity.

The coating system was salt spray tested for approx. 2000 h* without loss of the surface protection in accordance to ISO 9227. * Without damaging the surface

To ensure the lifespan of the paint, the product must be maintained in line with the recommended maintenance schedule

Colour (Standard)

Crash beam	RAL 9010 pure white
Cover plate crash beam	RAL 9010 pure white
Guide stands	RAL 9010 pure white
Ground frame	RAL 9010 pure white
Ground sleeves	primed (dark grey)
Drive cabinet	RAL 7035 light grey

Colour (Optional)

Crash beam	Striped RAL 3000 flame red / RAL 9010 pure white RAL 3000 flame red or any RAL colour or DB colour
Cover plate crash beam	Any RAL colour or DB colour
Guide stands	Any RAL colour or DB colour
Ground frame	Any RAL colour or DB colour

Temperature Range

-20°C to + 60°C

As our policy is to continually improve the products we offer, we reserve the right to amend specifications without prior notice. Further product drawings are available on request

Document: 2091641

Version: b, changed: 30.08.2017